

<b>DTC</b>	<b>P0717</b>	<b>Input Speed Sensor Circuit No Signal</b>
------------	--------------	---

**DESCRIPTION**

This sensor detects the rotation speed of the turbine which shows the input revolution of the transmission. By comparing the input turbine speed signal (NT) with the counter gear speed sensor signal (SP2), the ECM detects the shift timing of the gears and appropriately controls the engine torque and hydraulic pressure according to various conditions, providing smooth gear shifts.

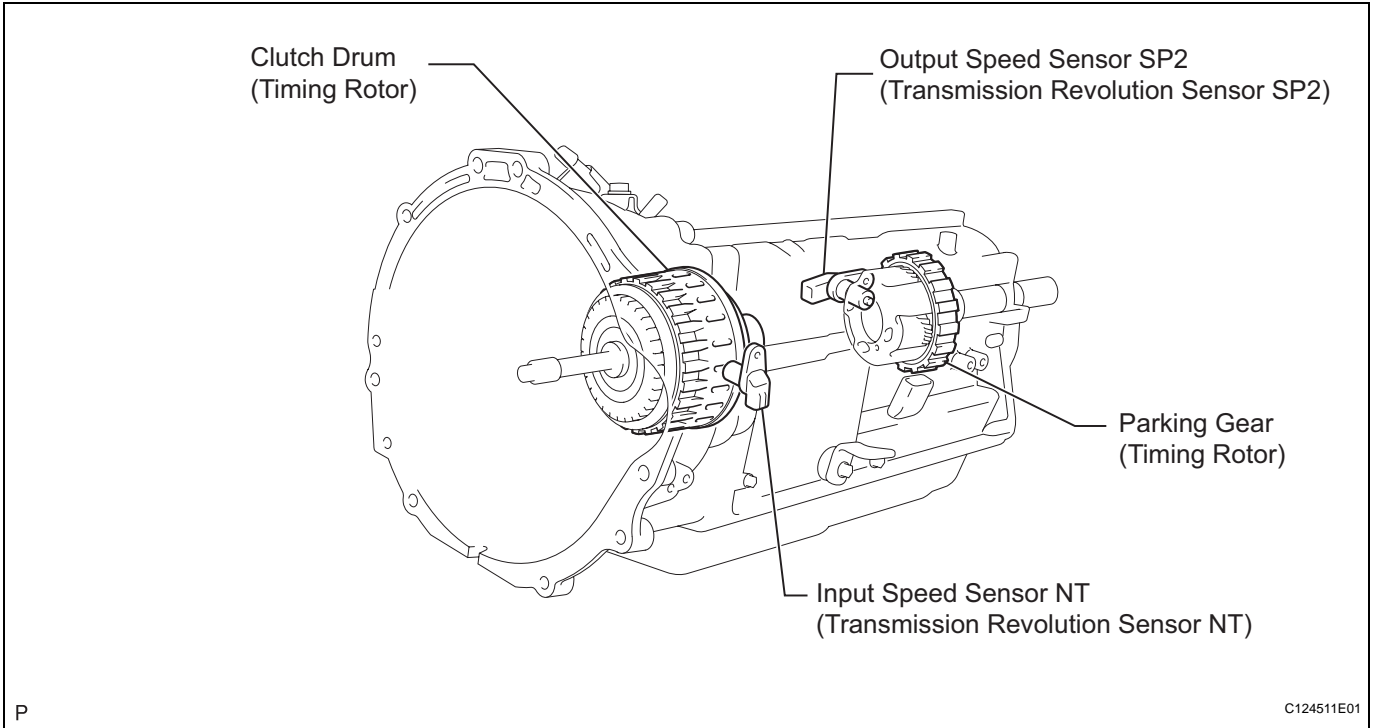

DTC No.	DTC Detection Conditions	Trouble Areas
P0717	All conditions below are detected for 5 seconds or more. (1-trip detection logic) (a) Gear change is not being performed. (b) Gear position: 4th or 5th (c) T/M input shaft rpm: 300 rpm or less (d) T/M output shaft rpm: 1,000 rpm or more (e) Park/neutral position switch (NSW, R and L) is OFF (f) Shift solenoid valves, park/neutral position switch and vehicle speed sensor are in normal operation.	<ul style="list-style-type: none"> <li>• Open or short in speed sensor (NT) circuit</li> <li>• Speed sensor (NT)</li> <li>• ECM</li> </ul>

AT

Reference (Using an oscilloscope):

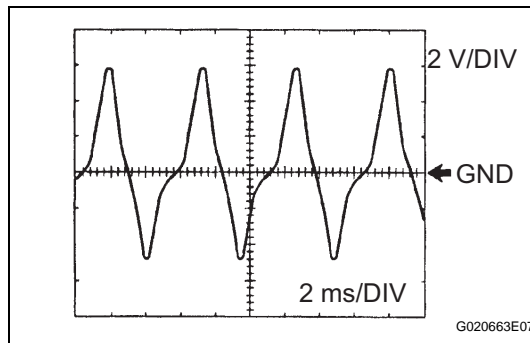

Check the waveform between terminals NT+ and NT- of the ECM connector.

**Standard:**

**Refer to the illustration.**

Item	Condition
Terminal	NT+ - NT-
Tool setting	2 V/DIV, 2 ms/DIV
Vehicle condition	Engine idling speed (P or N position)

## MONITOR DESCRIPTION

This DTC indicates that a pulse is not output from the speed sensor NT (Turbine (input) speed sensor) or is weak. The NT terminal of the ECM detects the revolution signal from the speed sensor (NT) (input RPM). The ECM outputs a gearshift signal comparing the input speed sensor (NT) with the output speed sensor (SP2). While the vehicle is operating in the 4th or 5th gear position in the shift position of D, if the input shaft revolution is less than 300 rpm\*1 although the output shaft revolution is more than 1,000 rpm or more\*2, the ECM detects the trouble, illuminates the MIL and stores the DTC.

\*1: Pulse is not output or is irregularly output.

\*2: The vehicle speed is approximately 31 mph (50 km/h) or more.

## MONITOR STRATEGY

Related DTCs	P0717: Speed sensor (NT)/Verify pulse input
Required sensors/Components (Main)	Speed sensor (NT)
Required sensors/Components (Related)	Speed sensor (SP2)
Frequency of operation	Continuous
Duration	5 seconds
MIL operation	Immediate
Sequence of operation	None

## TYPICAL ENABLING CONDITIONS

The monitor will run whenever the following DTCs are not present.	P0500: VSS P0748 - P0799: Trans solenoid (range)
Shift change	Each shift change is completed before starting next shift change operation
ECM selected gear	4th or 5th
Output shaft rpm	1,000 rpm or more
Park/neutral position switch	OFF
R switch	OFF
L switch	OFF
Engine	Running
Ignition Switch	ON
Starter	OFF

## TYPICAL MALFUNCTION THRESHOLDS

Sensor signal rpm	Less than 300 rpm
-------------------	-------------------

## COMPONENT OPERATING RANGE

Speed sensor (NT)	Input speed is equal to engine speed when lock-up ON
-------------------	--

**WIRING DIAGRAM**

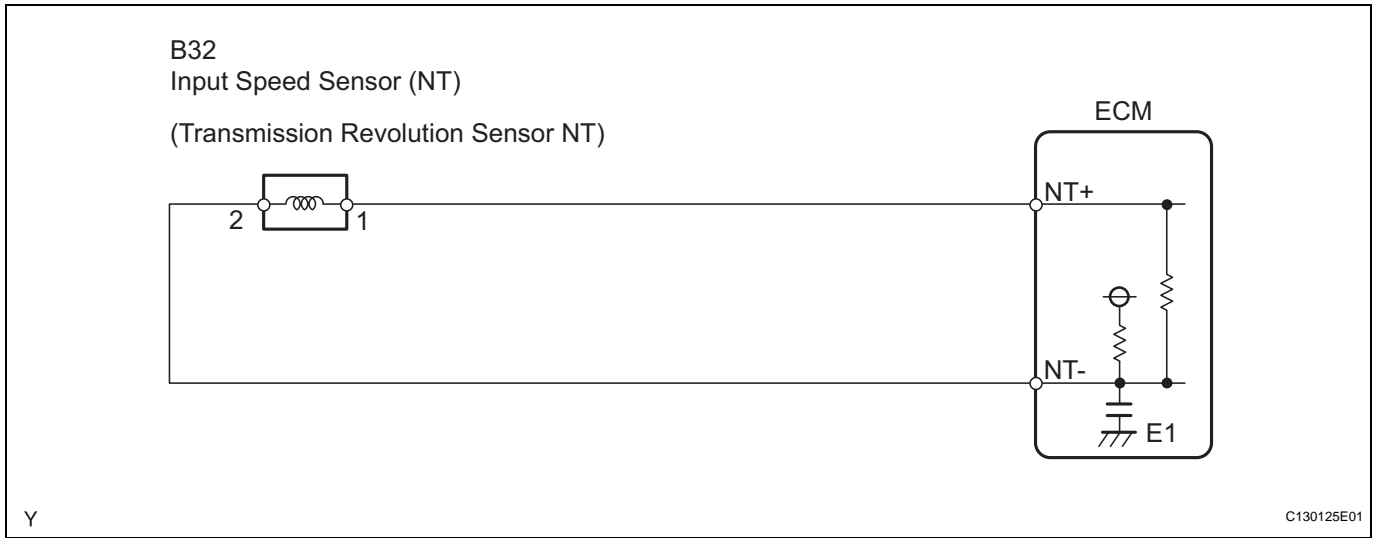

**INSPECTION PROCEDURE**

**HINT:**

According to the DATA LIST displayed on the intelligent tester, you can read the values of components, such as the switches, sensors and actuators, without removing any parts. Reading the DATA LIST as a first step of troubleshooting is one method of shortening labor time.

1. Warm up the engine.
2. Turn the ignition switch off.
3. Connect the intelligent tester together with the CAN VIM (Controller Area Network Vehicle Interface Module) to the DLC3.
4. Turn the ignition switch to the ON position.
5. Push the "ON" button of the tester.
6. Select the items "DIAGNOSIS / ENHANCED OBD II / DATA LIST / A/T".
7. According to the display on the tester, read the "DATA LIST".

Item	Measurement Item/ Range (display)	Normal Condition
SPD (NT)	Input Turbine Speed/ display: 50 rpm	<p>[HINT]</p> <ul style="list-style-type: none"> <li>• Lock-up ON (After warming up the engine); Input turbine speed (NT) equal to the engine speed.</li> <li>• Lock-up OFF (Idling at N position); Input turbine speed (NT) nearly equal to the engine speed.</li> </ul>

**HINT:**

- SPD (NT) is always 0 while driving:  
Open or short in the sensor or circuit.
- SPD (NT) is always less than 300 rpm while driving the vehicle at 31 mph (50 km/h) or more:  
Sensor trouble, improper installation, or intermittent connection trouble of the circuit.

**1 INSPECT SPEED SENSOR (NT) INSTALLATION**

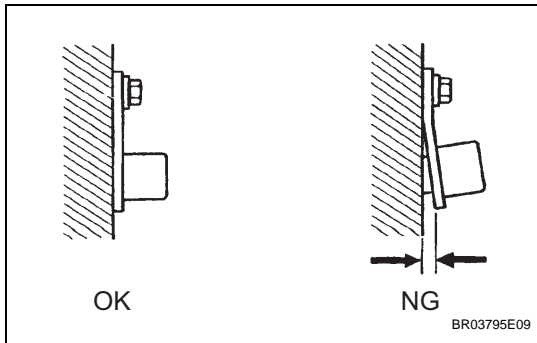

(a) Check the speed sensor (NT) installation.

**OK:**

The installation bolt is tightened properly and there is no clearance between the sensor and transmission case.

**NG** SECURELY INSTALL OR REPLACE SPEED SENSOR (NT)

**OK**

**2 INSPECT SPEED SENSOR (NT)**

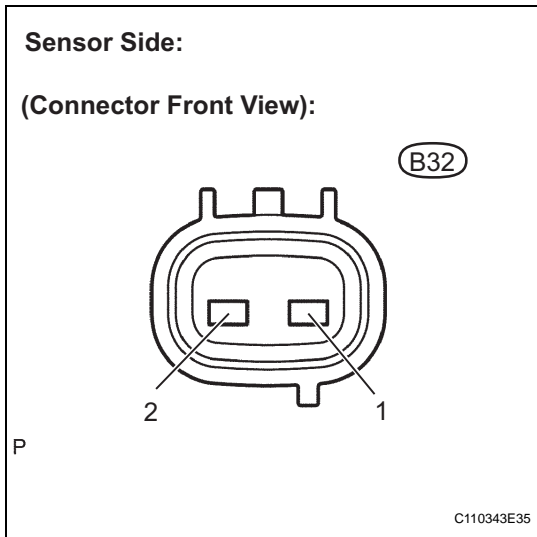

(a) Disconnect the speed sensor (NT) connector from the transmission.

(b) Measure the resistance.

**Standard resistance**

Tester Connection	Specified Condition
1 - 2	560 to 680 Ω at 20°C (68°F)

**NG** REPLACE SPEED SENSOR (NT)

**OK**

**3 CHECK HARNESS AND CONNECTOR (SPEED SENSOR (NT) - ECM)**

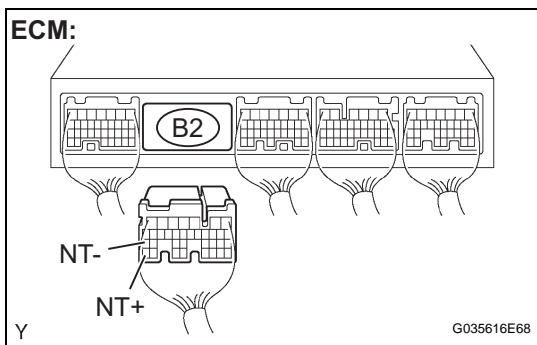

(a) Connect the speed sensor (NT) connector.

(b) Disconnect the ECM connector.

(c) Measure the resistance.

**Standard resistance**

Tester Connection	Specified Condition
B2-35 (NT+) - B2-27 (NT-)	560 to 680 Ω at 20°C (68°F)

(d) Measure the resistance.

**Standard resistance (Check for short)**

Tester Connection	Specified Condition
B2-35 (NT+) - Body ground	10 kΩ or higher
B2-27 (NT-) - Body ground	10 kΩ or higher

NG

REPAIR OR REPLACE HARNESS OR  
CONNECTOR

OK

REPLACE ECM